

50A Dual-Feed 5/5 GMT Total Front Access Fuse Panel



Applies to : GMT05FA

50A Dual-Feed 5/5 GMT TFA Fuse Panel

Power :: Model GMT05FA

Table of Contents

- 1.1 Overview 3
- 1.2 Rack-Mounting Considerations..... 4
- 1.3 Specifications..... 4
- 1.4 Installation..... 6
 - 1.4.1 Installation Considerations..... 6
 - 1.4.2 Mounting the Panel 7
- 1.5 Accessories..... 12
- 1.6 Assembly Drawing 13
- 1.7 Schematic..... 14

List of Figures

- Figure 1 - Brackets Oriented for Wall Mounting..... 3
- Figure 2 - Brackets Oriented for Rack Mounting 3
- Figure 3 - 23" Rack Mount 7
- Figure 4 - 19" Rack Mount 7
- Figure 5 - 19" Rack Mount Flush 7
- Figure 6 - 23" Rack Mount Flush 7
- Figure 7 - Rack Mounting 8
- Figure 8 - Wall Mounting..... 8
- Figure 9 - Ground Lug Connection 9
- Figure 10 - Input Connections 9
- Figure 11 - Status LEDs & Alarm Terminals..... 10
- Figure 12 - Output Connections..... 11
- Figure 13 - Installing GMT Fuses 11

50A Dual-Feed 5/5 GMT TFA Fuse Panel

Power :: Model GMT05FA

1.1 Overview



Figure 1 - Brackets Oriented for Wall Mounting



Figure 2 - Brackets Oriented for Rack Mounting

The Telect 50A Dual-Feed 5/5 GMT Total Front Access Fuse Panel is a compact 1RU, EIA panel enabling ± 24 and -48 VDC power protection for a variety of local/remote central office, datacenter and cell-tower telecommunications equipment.

The panel provides total front access to inputs, outputs, alarms, LED indicators and fuses. Its small form factor — less than 2 in. (~ 50 mm) in depth — makes it ideal for mounting to either front or rear rack flange. Re-orient mounting brackets to install on a wall.

Each of the 50A feeds provides power for up to 5 GMT-protected loads of up to 15A each. The GMT fuse blocks are mounted upside-down so that the GMT indicator flag flips downward when activated, making identification and detection easier, especially on tall racks. Holes for color coded fuse designation pins are located above each fuse position.

50A Dual-Feed 5/5 GMT TFA Fuse Panel

Power :: Model GMT05FA

Other features include power and fuse fail LEDs for each feed plus dry Form-C alarm connections for both power and fuse failures. Visit our website (www.telect.com) or see Page 10 to order GMT fuses and fuse designation pins. GMT05FA is listed by UL for USA and Canada, and NEBS (Level 3) certified.

1.2 Rack-Mounting Considerations

- 1. Elevated Operating Ambient** - If the equipment is installed in a closed or multi-unit rack assembly, the operating ambient temperature of the rack environment may be greater than room ambient. Therefore, give consideration to installing the equipment in an environment compatible with the maximum ambient temperature (T_{ma}) specified by the manufacturer.
- 2. Reduced Air Flow** - Installation of the equipment in a rack should be such that the amount of air flow required for safe operation of the equipment is not compromised.
- 3. Mechanical Loading** - Mounting of the equipment in the rack should be such that a hazardous condition is not achieved due to uneven mechanical loading.
- 4. Circuit Overloading** - Consider the connection of the equipment to the supply circuit and the effect that overloading of the circuits might have on overcurrent protection and supply wiring. Use appropriate consideration of equipment nameplate ratings when addressing this concern.
- Maintain reliable earthing of rack-mounted equipment. Pay particular attention to supply connections other than direct connections to the branch circuit (e.g., use of power strips).

1.3 Specifications

Inputs:	Specifications:
Voltage & Range	±20 VDC to -60 VDC @ 20°C ±22 VDC to -58 VDC @ 55°C
Max. Input Load Rating	50A
Max. Power Dissipation at Full Load	11W per side
% of Full Load Power Dissipation	Less than 1%
Max. Input Interruption Device	60A
Input Terminals	Dual M5 studs on 5/8-in. centers. Torque KEPS nut (using 5/16-in. or 8-mm socket) to ~20 in.-lb (~2.3 N•m).
Input Wire Size	8 AWG for a 50A feed

50A Dual-Feed 5/5 GMT TFA Fuse Panel

Power :: Model GMT05FA

Outputs:	Specifications:
Max. GMT Output Fuse (ea.)	15A
Max. GMT Output Load (ea.)	12A continuous
Max. Total GMT Output Per Side	50A
Output Terminals	10 pairs of 6-32 panhead compression/wire-binding terminals
GMT Output Wire Size Range	#26 to #14 AWG, depending on output fuse (1/4A to 15A)

Alarms:	Specifications:
Alarm Relay Contacts	Dry Form-C contacts (1A @ 30 VDC)
Max. Alarm Power Rating	@24V: 24 mA (0.58W) @48V: 48 mA (2.30W)
Alarm Wire Size	Up to 16 AWG
Alarm Terminals	# 3 panhead screws with wire-binding plates
Amphenol-Type Connector (Unshielded) 64 Pins	

Environmental:	Specifications:
Operating Temperature Range	-10°C (14°F) to 55°C (131°F)

Physical (Nominal):	Specifications:
Width x Height x Depth	17.25" x 1.75" x 2" (438 mm x 44 mm x 50 mm) See Page 11 for details.
Weight (Installed)	3.6 lb (1.6 kg)
Weight (Shipping)	~4.0 lb (~1.8 kg)
Material & Color	Steel (grey powder coat)
Mounting Options	Wall or EIA Rack (19 in. and 23 in.)

Grounding:	Specifications:
Chassis GND Terminal Studs (With KEPS Nuts) for Single-Hole Compression Lug	1/4"-20 stud. Torque KEPS nut (using 7/16-in. socket) to ~20 in.-lb (~2.3 N•m).

50A Dual-Feed 5/5 GMT TFA Fuse Panel

Power :: Model GMT05FA

1.4 Installation

ALERT

ALERT! Install this product within a restricted access location where access is through the use of a tool, lock and key, or other means of security and is controlled by the authority responsible for the location.

Only qualified personnel may install and maintain this product

ALERT

ALERT! Verify that all connections meet requirements specified in local electric codes or operating company guidelines before supplying power. Protect this equipment with a fuse or breaker sufficient to interrupt power levels specified under “Inputs” on the preceding table of specifications.

1.4.1 Installation Considerations

Please read and understand all instructions before starting installation. If you have questions, contact Telect Technical Support at getinfo@telect.com or call 1.509.926.6000.

When you receive the equipment, carefully unpack it and compare it to the packaging list. Please report any defective or missing parts to Telect Quality at getinfo@telect.com or call 1.509.926.6000.

Telect is not liable for transit damaged. If the product is damaged, please report it to the carrier and contact Telect Quality at getinfo@telect.com.

50A Dual-Feed 5/5 GMT TFA Fuse Panel

Power :: Model GMT05FA

1.4.2 Mounting the Panel

NOTE: Panel brackets provide flush or extended mounting on an EIA, 19" or 23" rack. The mounting brackets also allow for flush or extended mounting on a wall.

Procedure steps:

1. Install the brackets using the four screws included with brackets, as shown in the following illustrations.
2. Mount the panel using the screws provided, as shown.



Figure 3 - 23" Rack Mount, Extended or Wall-Mounted



Figure 4 - 19" Rack Mount, Extended or Wall-Mounted



Figure 6 - 23" Rack Mount Flush



Figure 5 - 19" Rack Mount Flush

50A Dual-Feed 5/5 GMT TFA Fuse Panel

Power :: Model GMT05FA

- For rack mounting, locate an unused EIA rack position, normally at the top of the rack. Mount the panel to the rack using the four, 12-24 thread-cutting screws and washers provided, as shown on the right. Tighten the screws to 35 in.-lb (4.29 N•m).
- For wall mounting, use four appropriate fasteners (and anchors, if needed) along with the #12 washers provided.

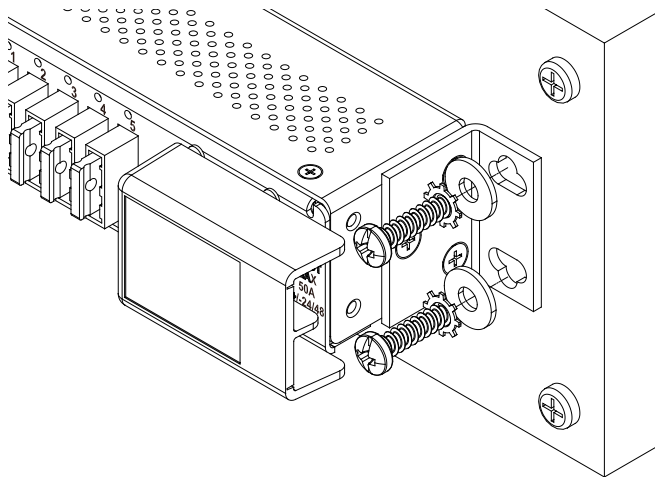

Figure 8 - Wall Mounting

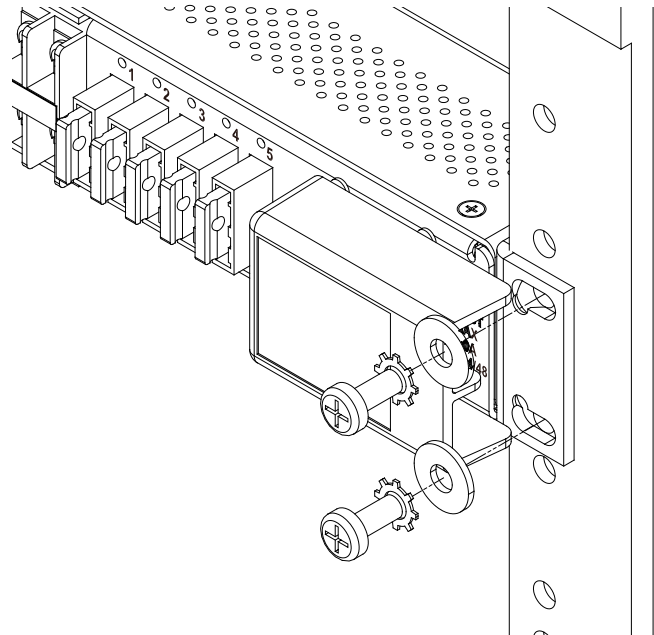

Figure 7 - Rack Mounting

It is best to mount the panel on a plywood board that has been securely anchored to the wall. If you mount the panel on a metal strut, in a cabinet, or onto other metal objects, make sure to ground the metal object along with the panel.

WARNING

WARNING! Failure to properly ground this equipment can create hazardous conditions to installation personnel and to the equipment.

ALERT

ALERT! Only use components and crimping tools approved by agencies or certifying bodies recognized in your country or region such as Underwriter's Laboratories (UL), TUV, etc.

50A Dual-Feed 5/5 GMT TFA Fuse Panel

Power :: Model GMT05FA

- Use a listed (approved) crimping tool to attach a listed (approved), single-hole compression lug for a #10 stud onto 14 AWG ground wire.

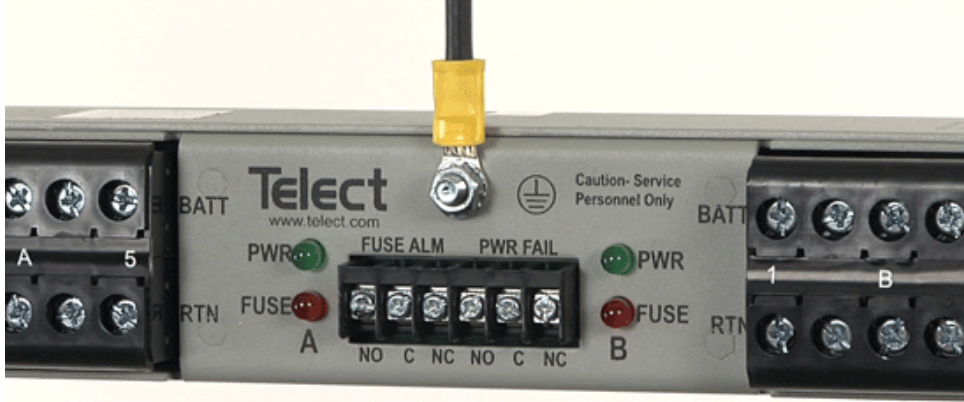

Figure 9 - Ground Lug Connection

- If desired (highly recommended), lightly coat antioxidant on lug, grounding terminal and surrounding contacting surface.
- Connect the lug using the M5 KEPS nut provided, as shown on the right. Tighten the KEPS nuts to ~20 in.-lb (~2.3 N•m).
- The installer should verify that a readily accessible 60-amp maximum overcurrent protection device is part of the building installation wiring feeding the fuse panel.
- Make sure the input power is OFF (open breaker, dummy fuse, or open fuse holder at power distribution unit, PDU, before connecting this panel’s input cables to the PDU.

WARNING

WARNING! Before connecting input power cables, make sure input power to panel is turned off.

- For input wiring — wiring used as inputs to this distribution panel — crimp the dual-hole compression lugs onto #10 to #6 AWG conductors (min. 8 AWG for a 50A feed).
- Insulate the lug barrels with UL94 V-0 rated heat-shrink tubing.

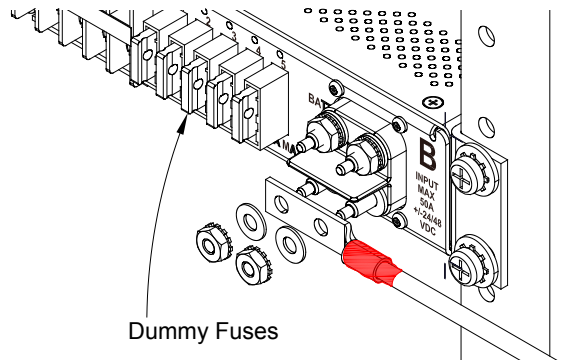
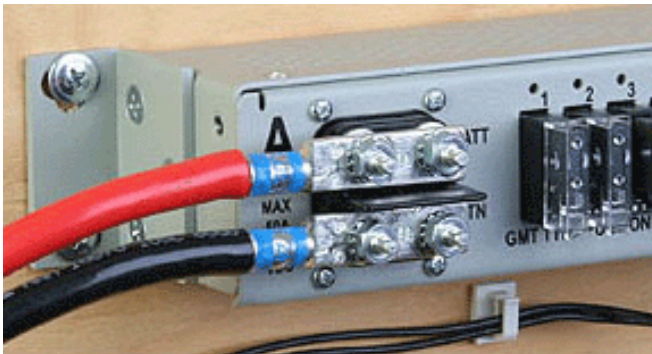

Figure 10 - Input Connections

50A Dual-Feed 5/5 GMT TFA Fuse Panel

Power :: Model GMT05FA

10. Remove (pull off) the input terminal covers.
11. Clean terminals and lugs with a non-abrasive, non-metallic cloth or pad.
12. If desired (highly recommended), lightly coat antioxidant on lugs, terminals, and contacting surfaces and then connect lugs to input terminals on panel.
13. Torque the KEPS nuts to ~20 in.-lb (~2.3 N•m).
14. Re-install the input terminal covers.
15. Make sure the GMT fuse positions are either empty or contain dummy fuses (phoney, inoperative all-plastic slugs).
16. Enable the fuse or breaker at the PDU (60A max.) to turn on Feed A to Side A of panel and then check voltage and polarity at input connectors of panel. Also, check that:
 - **PWR A** LED on front of panel turns ON (green)
 - **PWR B** and both FUSE LEDs must be OFF
17. With **PWR A** lit (green for normal operation) — but with **PWR B** LED off — test power-fail relay and contacts at **PWR FAIL** terminals on panel:
 - Expect an open circuit (00 Ω) between **Terminals C** and **NC**
 - Expect continuity (0 Ω) between **Terminals C** and **NO**
18. Test the fuse alarm relay contacts at **FUSE ALM** terminals:
 - Expect continuity (0 Ω) between Terminals **C** and **NC**
 - Expect an open circuit (00 Ω) between Terminals **C** and **NO**
19. Repeat Steps 16 and 17 to power up Side B
 - **PWR A** and **PWR B** must both be green
20. With **PWR A** and **B** lit, test power-fail relay and contacts at **PWR FAIL** terminals:
 - Expect continuity (0 Ω) between Terminals **C** and **NC**
 - Expect an open circuit ($\infty\Omega$) between Terminals **C** and **NO**
21. Make sure none of the fuse positions contain real, operable fuses.



Figure 11 - Status LEDs & Alarm Terminals

50A Dual-Feed 5/5 GMT TFA Fuse Panel

Power :: Model GMT05FA

22. For GMT output wiring, use #24 to #14 AWG copper wire. (Work with one wire at a time.) At this end of the wire, either:
 - Crimp a single-hole ring or fork lug, as required by NEC
 - Strip 3/8 in. (10 mm) of insulation for a bare-wire connection
23. Clean the panel terminals and lug (if applicable) with a non-abrasive, non-metallic cleaning pad.
24. If required, lightly coat antioxidant on lug/wire and output **BATTERY** and **RETURN** terminals, and then connect to the terminals. (NEC specifies only one load at each output terminal.)
25. Tighten the panhead screws to no greater than 8 in.-lb (~1 N•m) and then connect the other end of the output wire to load.

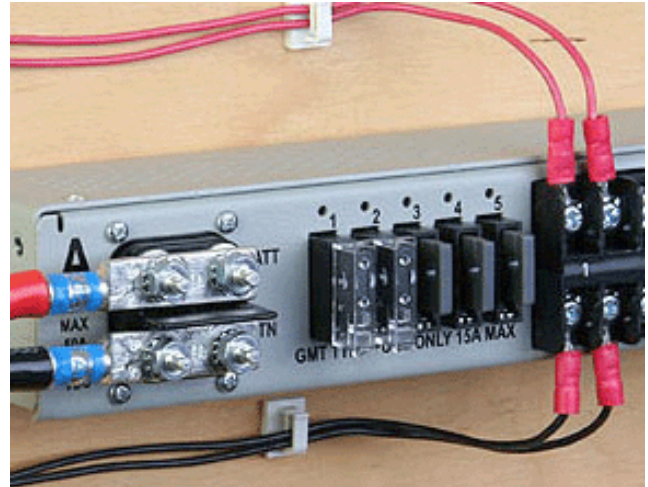

Figure 12 - Output Connections

! ALERT

ALERT! GMT fuses have a small inherent electrical resistance resulting in a small inherent power loss. For this reason, the GMT fuse manufacturer recommends that the load for GMT fuses up to and including 7.5A not exceed 80% of the fuse rating and that the load for GMT fuse sizes between 10A and 15A not exceed 70% of the fuse rating. For example, the load for a 15A GMT fuse should not exceed 10.5A (15A x .70 = 10.5A).

The TOTAL LOAD FOR ALL FUSE OUTPUTS ON EACH SIDE must NOT exceed 50A.

26. Make sure load devices are off (disabled) and then install the GMT fuses. Remember to install the GMT fuses so that the failure indication flags are at the bottom, as shown in the following illustration.
27. Test power and polarity at input of each equipment load.
28. If possible, replace one of the operable GMT fuses with a blown fuse to verify that the **FUSE Alarm** LED and **FUSE ALM** terminals are also as specified above.
29. Re-install the operable GMT fuse before proceeding.
30. If desired, connect the remote external audio/visual alarm indicator wires (solid or tinned wires, #22 to #18 AWG) to **PWR ALARM** and **FUSE ALM** terminals.
31. Enable the equipment loads one at a time to verify proper operation of loads.

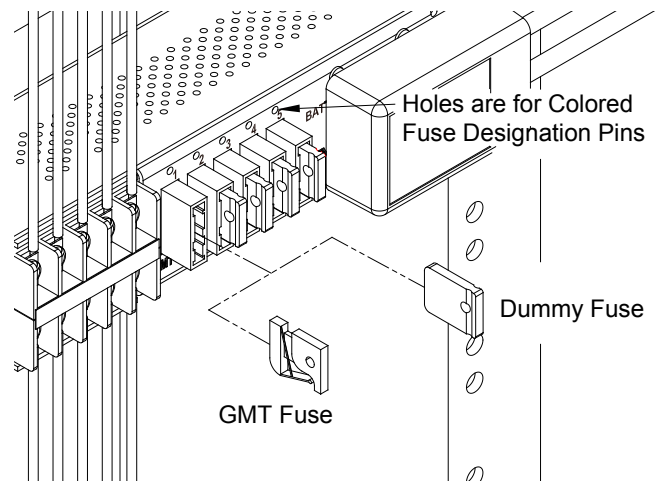

Figure 13 - Installing GMT Fuses

This procedure is complete.

50A Dual-Feed 5/5 GMT TFA Fuse Panel

Power :: Model GMT05FA

1.5 Accessories

The following lists optional and replacement items for the panel. For compression lugs, please refer to Wire Sizing & Label Convention Chart (Telect Part No. 117995) included with your panel.



WARNING

WARNING! Use only UL-listed fuses or UL-recognized component secondary protection devices.

For dummy fuses, order part number 132748. For GMT safety (splash/splatter) covers, order part number 116915. Telect recommends using only UL-recognized supplementary protectors.

Table 1 - GMT Fuses

GMT Fuse	Part Numbers GMT Fuse	Colored Designation Pin Part No.
.18A Yellow (YEL)	130781	102435-21
¼A Violet (VIO)	100151	102435-2
½A Red (RED)	004001	102435-5
¾A Brown (BRN)	004008	102435-7
1A Gray (GRY)	100991	102435-8
1-1/3A White (WHT)	004006	102435-9
1-½A White/Yellow (WHT/YEL)	004011	102435-10
2A Orange (ORN)	004002	102435-11
2.5A White/Orange (WHT/ORN)	130783	102435-12
3A Blue (BLU)	004012	102435-13
3.5A White/Blue (WHT/BLU)	130782	102435-14
4A White/Brown (WHT/BRN)	004013	102435-15
5A Green (GRN)	004014	102435-16
7-½A Black/White (BLK/WHT)	004010	102435-17
10A Red/White (RED/WHT)	004015	102435-18
12A Yellow/Green (YEL/GRN)	102287	102435-19
15A Red/Blue (RED/BLU)	102288	102435-20

**Table 2 - Input Lugs for Stranded Copper Conductors
(Straight Dual-Hole Lugs for #10 Studs on 5/8" Centers)**

Manufacturer	#6 AWG	#8 AWG
T & B	256-30695-1183 (T&B Die Code 24)	54204 (T&B Die Code 49)
Panduit	LCD6-10A-L (Panduit/T&B Die Code 24) (Burndy Die Code 7)	LCD8-10A-L (Panduit/T&B Die Code 21) (Burndy Die Code 49)
Burndy	YA6CL2TC10 (Burndy Die Code 7)	YA8CL2TC10 (Burndy Die Code 49)

50A Dual-Feed 5/5 GMT TFA Fuse Panel

Power :: Model GMT05FA

1.7 Schematic

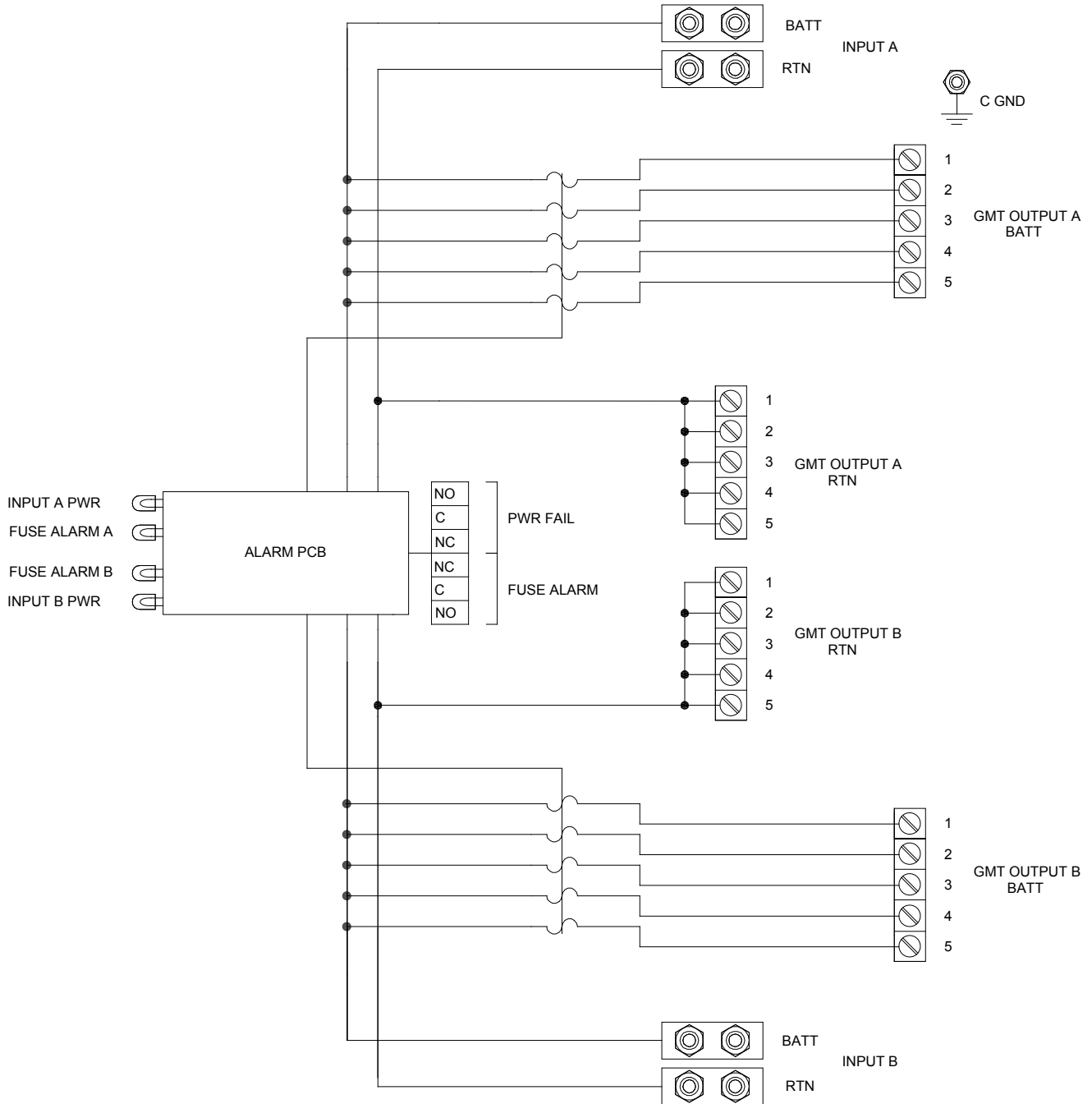

Telect assumes no liability for the application or use of these products. Neither does Telect convey any license under its patent rights or the patent rights of others. This document and the products described herein are subject to change without notice.