

1RU Fiber Splice Shelf Gen 3

Installation Guide



Installation Guide, 1RU Fiber Splice Shelf Gen 3

Copyright 2020, Amphenol Network Solutions, All rights reserved.

Amphenol Network Solutions
22425 E. Appleway Ave #11
Liberty Lake, WA 99019

Amphenol Network Solutions assumes no liability from the application or use of these products. Neither does Amphenol Network Solutions convey any license under its patent rights nor the patent rights of others. This document and the products described herein are subject to change without notice.

About

Amphenol Network Solutions is a global innovative original equipment manufacturer that serves the data and communications markets. We design, manufacture, and distribute products for customers who need an end to end solution for network connectivity, fiber, power distribution and rack management. We collaborate with our customers to deliver product solutions that exceed expectations with innovative designs and world class quality. Amphenol Network Solutions is the industry thought leader on network cable management.

Technical Support

Email: support@amphenol-ns.com
Phone: 509.926.6000

Table of Contents

1. General Product Information	4
2. Safety Precautions	4
3. Tools Required.....	4
4. Package Contents.....	4
Installing the Product.....	5
5. Unpacking.....	5
6. Mounting	5
7. Splice Tray Installation.....	5
8. Module and Pre-terminated Cable Routing.....	6
9. Cable Preparation for Splicing	6
10. Loading Adapters Panels or Modules	7
11. Grounding	8
12. Jumper Routing.....	8
13. Connector Cleaning	9
14. Customer Service	9

1. General Product Information

Overview

Amphenol Network Solutions' Fiber Splice Shelf Gen 3 is designed to enable quick and easy fiber splicing and connectivity for indoor applications. This product requires some assembly and it is recommended that these instructions are read before starting the installation. The splice shelf layout enables a variety of splicing and patching combinations. Accessibility is increased by removable front and rear panels.



2. Safety Precautions

⚠ ALERT

Danger: Direct eye exposure to laser light will cause serious eye damage. Avoid looking directly into an optical fiber, optical connector or optical adapter that is connected to an active source.

⚠ WARNING

Warning: Wear safety glasses to prevent accidental eye injury. Wear protective gloves and clothing to prevent accidental injury.

Warning: Observe company policies and procedures regarding personal safety.

Warning: Follow local and national safety and construction codes.

⚠ CAUTION

Caution: Handle fiber optic cable per manufacturer's recommendation for minimum bend radius, maximum tensile loading, and maximum crush resistance.

3. Tools Required

- 216 Tool
- #2 Phillips Screwdriver
- Fiber Optic Cleaning Supplies
- Cable Preparation Tools

4. Package Contents

- Fiber Splice Shelf
- FS3 Standard Sub-Assembly Kit o Cable clamp
 - o Routing rings
 - o Tie wraps
 - o Mounting brackets
 - o Mounting screws
 - o Installation Instructions
- Additional component kits per ordered configuration

The Fiber Splice Shelf is a modular and configurable product. Multiple component kits are available for this product that encompass a wide range of components for varied applications. Component kits may be selected at the time of order using the ordering guide section of the product datasheet.

Installing the Product



Fig. 1



Fig. 2



Fig. 3

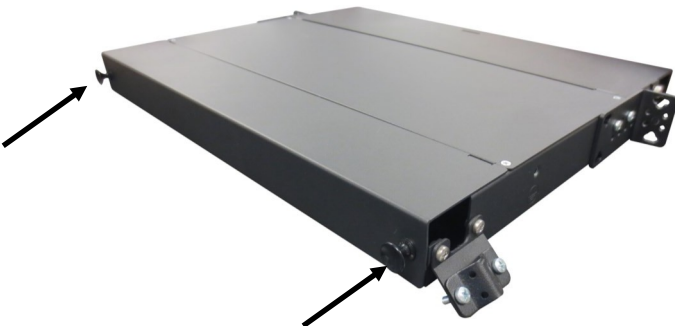

Fig. 4

5. Unpacking

Ensure all components are available per the configuration ordered.

6. Mounting

1. Locate the provided two mounting brackets and four 5/16" long Phillips head screws in the Standard Sub- Assembly Kit

Typical mounting for a 19" Rack with 4.5" front extension is highlighted in the illustration (Fig. 1).

The mounting brackets provide 9 possible front extension mounting positions.

2. For 19" Rack mounting, be sure that the long side of the bracket lays against the shelf.
3. For 23" Rack mounting, be sure that the short side of the bracket lays against the shelf.
4. Attach the brackets to the shelf for the desired frame width and front extension.
5. To mount the shelf to the Rack, use the provided 12- 24 x 1/2 Phillips head screws located in the Standard Sub-Assembly Kit.

Optional flush mount brackets are available as an accessory (Fig. 2). See data sheet for options.

7. Splice Tray Installation

Refer to the Splice Tray Installation Instructions for additional details. For additional access to splice area remove front and rear panels. To remove front (top) access panel loosen side thumb screws and pull panel forward (Fig. 3). To remove rear panel pull out pushpins in rear (Fig. 4). Choose a splice tray location based on cable entry, fiber routing and bulkhead usage (see following examples).

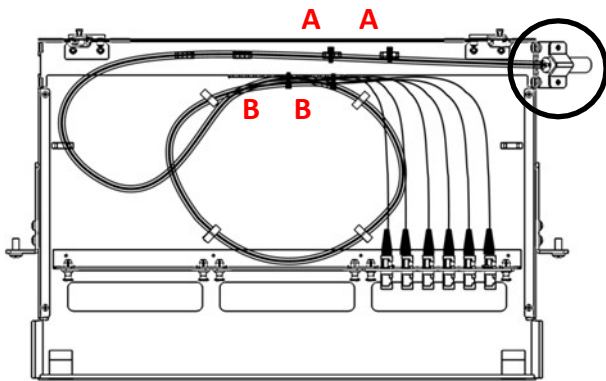

Fig. 5

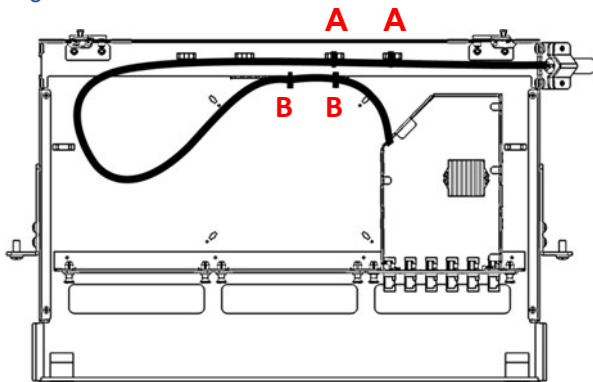

Fig. 6

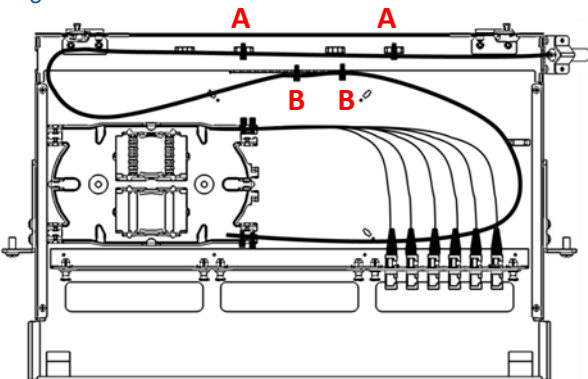

Fig. 7

8. Module and Pre-terminated Cable Routing

Fiber layout is at the discretion of the user or installer as long as the minimum bending radius of 1.5" is not violated. Suggested layouts for direct termination, module termination, and pigtail splicing are below (Fig. 5-7)

1. Determine the side and direction of the cable entrance [Left or Right and From top or From bottom].
2. Mount the cable clamp bracket with the two ¼" long Phillips head screws provided.

Mounting the bracket for a cable entrance from the bottom right is illustrated as reference

Reference the ground section if grounding a non-dielectric cable is required.

3. Place the Cable Clamp Top from the Standard Sub-Assembly Kit and attach it over the cable to the cable bracket using the two ½" long Phillips head screws (Fig. 5 black circle).

Direct Termination

1. Secure the cable to the cable clamp and route the assembly as illustrated.
2. Using tie wraps to secure the assembly to both the shelf back [A] and the sliding drawer bulkhead [B].
3. Ensure there is enough slack to allow the drawer to extend completely before securing the tie wraps.

Module Termination

1. Secure the cable to the cable clamp and route the assembly as illustrated.
2. Using tie wraps secure the assembly to both the shelf back [A] and the sliding drawer bulkhead [B].
3. Ensure there is enough slack to allow the drawer to extend completely before securing the tie wraps.

9. Cable Preparation for Splicing

Buffer Tubes

1. Prep the cable by removing the sheath, yarns and any filler tubes.
2. Route the buffer tube around the inside of the drawer.
3. Ring cut the tube and expose the optical fibers.
4. Attach the tube to the splice tray with supplied tie-wraps. Use felt wrap as needed.
5. Route 1.5 service loops in the tray and trim fiber to length for splicing.

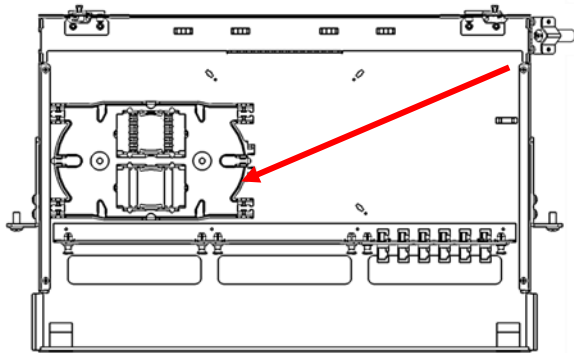

Fig. 8

Tray Splicing

1. Secure the cable to the cable clamp and route the buffer tube to the tray (Fig. 9).
2. Ensure there is enough fiber slack available for splicing before positioning to the tray.

The fiber pigtails should be routed over top of the buffer tube and secured to the tray.

3. Using four tie wraps, secure the assembly to both the shelf back [A] and the sliding drawer bulkhead [B] (Fig. 6).
4. Ensure there is enough slack to allow the drawer to extend completely before securing the tie wraps.

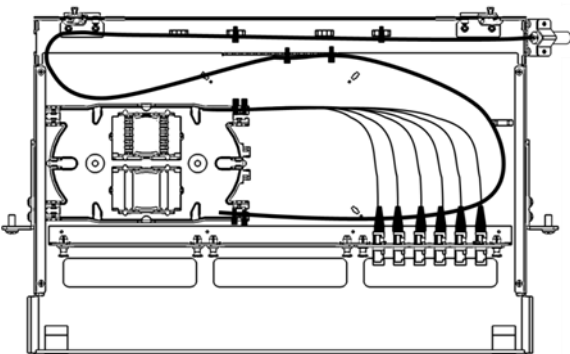

Fig. 9

Pigtails

1. Route the pigtails around the shelf drawer using the fiber routing rings to hold the pigtails (Fig. 9-10).
2. Position and manage the slack around inside of the drawer.
3. Mark and wrap pigtails with the supplied felt wrap. Attach the pigtails to the splice tray using the supplied tie-wraps.
4. Route 1.5 service loops in the tray and trim fiber to length for splicing.

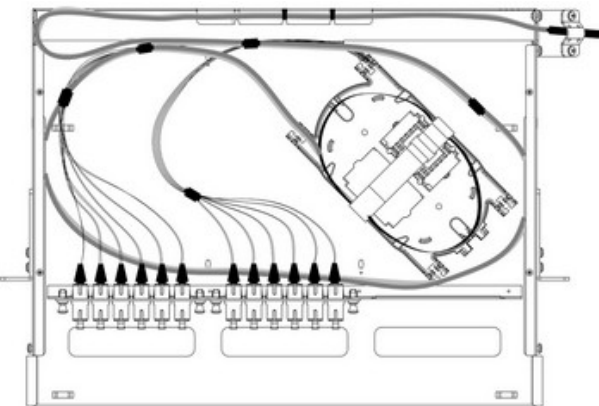

Fig. 10

The use of two bulkheads for patching and splicing is possible by positioning the tray(s) diagonally (Fig. 10). When stacking two trays position buckle strap on side of trays.

10. Loading Adapter Panels or Modules

Adapter Panels

1. From the front of the shelf remove an adapter panel knock-out blank in the shelf drawer bulkhead.
2. Insert the adapters into the adapter panel bulkhead.
3. Ensure the adapter key is always facing in the same direction [recommended: up] and that the adapter metal spring clip is on the same side [recommended: inside].
4. The adapter retainer should snap into position.
5. Starting with the first adapter [recommended: right to left] remove the dust covers and connect the pigtails one at a time.

It is strongly recommended to inspect and clean both connectors before making an optical connection.



Fig. 11

6. Position the adapter panel bulkhead in the desired opening and insert the mounting pins into the holes in the drawer.
7. Push on the mounting pin head to lock the panel in place.

11. Grounding

All grounding should follow local codes and practices.

When grounding a non-dielectric cable, the components required for this procedure are provided in the grounding kit.

1. Attach the B-bond clamp to the cable.
2. Attach the solid #6 AWG ground wire to the cable bonding clamp.

When grounding the shelf and a non-dielectric cable, the components required for this procedure are provided in the grounding kit.

1. Locate the threaded grounding hole on the cable clamp side of the shelf for the Ground Feed-Thru lug.
2. Attach the cable bonding clamp to the cable.
3. Attach the stranded #6 AWG jumper ground wire to the B-bond clamp and route the wire to the threaded grounding hole.
4. Thread the Ground Feed-Thru stud through the wire terminal and attach the Ground Feed-Thru to the shelf.
5. Attach the solid #6 AWG wire to the outside terminal of the Ground Feed-Thru (Fig 11).

12.0 Jumper Routing

Note: It is strongly recommended to inspect and clean both connectors before making an optical connection.

1. Install the jumper connector into the appropriate adapter.
2. Route the jumper slack out of the shelf to either side.
3. Route the jumper slack to minimize tight bending stress or tension at the connector boot.
4. Use the Velcro strap to bundle and secure the jumpers as they exit the shelf (Fig.12)



Fig. 12

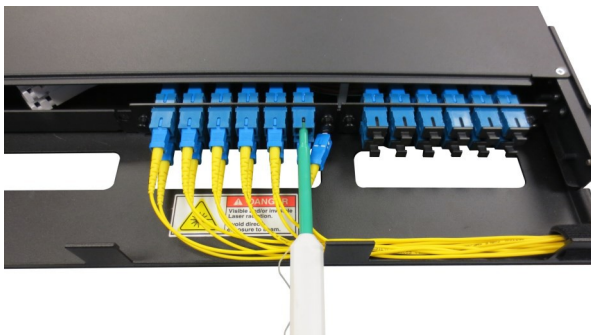

Fig. 13

13. Connector Cleaning

– Recommended prior to product usage

Note: Utilize connector and adapter protective caps whenever possible; however, this practice does not guarantee cleanliness of the optical interface.

Front access cutouts allow a cleaning tool to be inserted into an adapter without removal of the entire 6-pack or 12-pack adapter assembly (Fig. 13).

Before connecting, or after each disconnect, it is recommended to perform the following cleaning procedure. A connector inspection scope, lint-free wipes and optical cleaning solvent are necessary equipment.

This procedure conforms to the IPC 8491-1, “Cleaning Methods and Contamination Assessment for Optical Assembly.”

- Make sure the fiber is not active
- Remove the protective caps
- Gently wipe the connector ferrule end with a lint-free wipe
- Verify the cleanliness of the connector with an inspection scope
- If necessary, gently wipe the fiber end with a lint-free wipe moistened with a small amount of cleaning solvent. Then dry with a clean lint-free wipe
- Verify the cleanliness of the connector with an inspection scope

14. Customer Service

Please report any defective or missing parts to Amphenol Network Solutions Quality at quality@amphenol-ns.com or call 1-509-926-6000. Keep all documentation that comes with your shipment.

Please read and understand all instructions before starting installation. If you have any questions, contact Amphenol Network Solutions Technical Support at support@amphenol-ns.com or call 1-509-926-6000.

Exercise care when unpacking and setting the equipment in place. Amphenol Network Solutions is not liable for transit damage. If the product is damaged, please report it to the carrier and contact Amphenol Network Solutions Quality at quality@amphenol-ns.com.